



# -- LWZ-2 SERIES -- INSTALLATION & ADJUSTMENTS

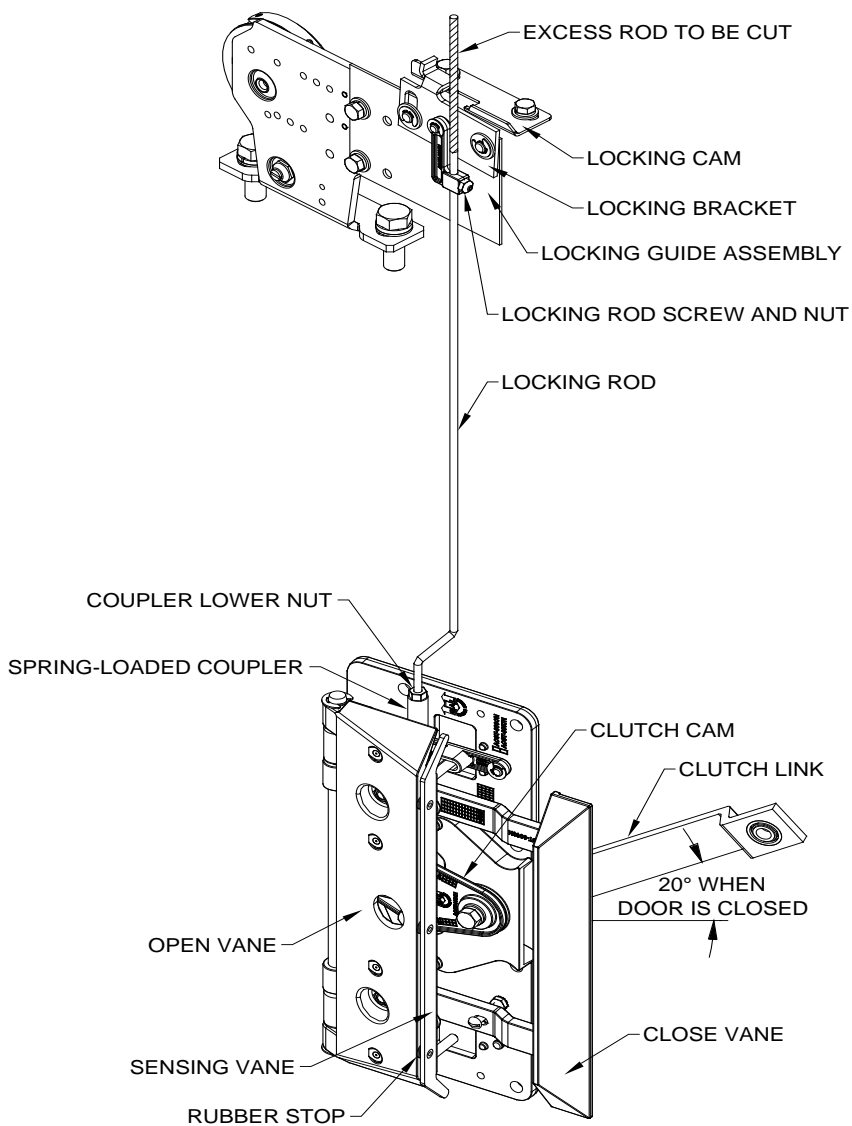
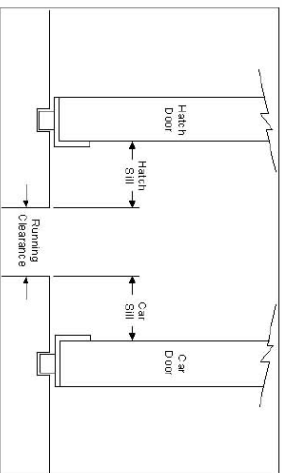
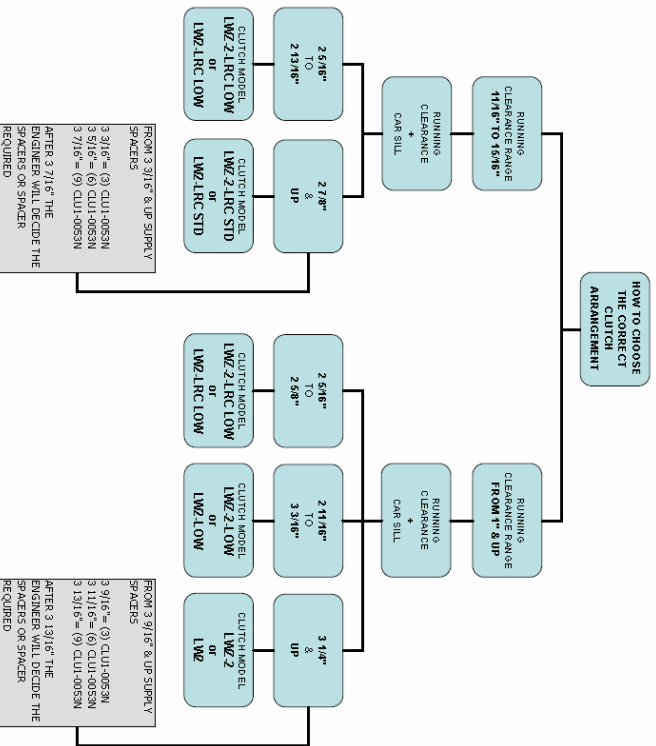

Fig. 1: LWZ-2 Clutch Assembly



G.A.L. Manufacturing Corporation  
 59 East 151<sup>st</sup> Street, Newark, N.J., 10651  
 Phone (718) 252-9000 Fax (718) 252-2034



# LWZ-2 Series

---

*Thank you for purchasing this LWZ-2 series clutch.  
GAL hopes that this manual will reduce the installation and adjustment time and result in a smooth long lasting operation.  
GAL strives to provide the highest quality products, on time, with outstanding customer support.*

## **Contents**

Required tools for installing & adjusting LWZ-2 series clutches.....	1
General installation and setup of the LWZ-2 clutch: .....	2
Standard setup of the clutch retracting vane:.....	2
Set up of zone lock: .....	3
Quick Set up of locking cam:.....	3
Zone Lock & Retracting Vane Timing.....	4
LRC (Limited Run Clearance) Clutch Adjustments: .....	6

---

## **Required tools for installing & adjusting LWZ-2 series clutches**

- 5/64" Allen Key
- 5/16" Socket Wrench
- 7/16" Socket Wrench
- 1/2" Socket Wrench
- 6" Scale Or Tape Measure
- Hack Saw
- File

**Note:** Open vane may be flipped open during installation for better access to mounting hardware. After mounting, please make sure that lock nuts are tightened to meet the required 2 1/8" from the base shown in Fig. 2. (For LRC styles, adjust the retracted position as described in the **LRC (Limited Run Clearance) Clutch Adjustments:** section on page 6)

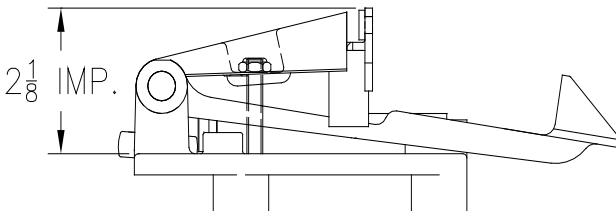

**Fig. 2: Open vane location**

# LWZ-2 Series

## **General installation and setup of the LWZ-2 clutch:**

G.A.L. provides car reinforcement and drilling templates for both new installations and modernization jobs.

(**Note:** The LWZ-2 uses the same mounting GAL mounting locations as older designs).

- Mount the LWZ-2 clutch (Located to the car door per the provided templates) using either six (6) 5/16-18 bolts or carriage bolts.
- Space the clutch out (Spacers shown in Fig. 3) from the car door face so that there is a minimum of 1/4" between the hatch sill and the outer edge of the clutch opening vane (See Fig. 4) at the tightest landing (**Note:** For **LRC models**, adjust the 1/4" hatch sill measurement with the clutch in the retracted position).
- Adjust the interlock release roller assemblies on all landings so that there is 3/8" from the roller face to the edge of the car sill. For a typical 1-1/4" running clearance, this will provide for an interaction of 5/8" between the rollers and the clutch.
- After mounting and locating the clutch, attach the operator drive arm (see Operator Setup Instructions for drive arm setup).

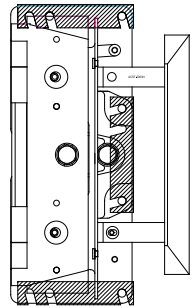

**Fig. 3: Arrangement of Clutch Spacers**

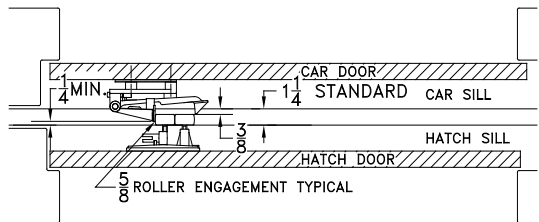

**Fig. 4: Locating the Clutch and release**

**CAUTION:** to avoid damage, the clutch link should be 20° from horizontal when the door is closed.

## **Standard setup of the clutch retracting vane:**

Once the pickup roller depth and position have been set properly, you need to adjust the retracting vane of the clutch so that it retracts as late as possible in the closing cycle. The rear vane should retract and clear the stationary roller in the pickup assembly by approximately 1/8" when the hoistway door reaches full closure. The point where the rear vane retracts is adjusted by turning the clutch cam (see Fig. 11: Open Vane Location, on page 8). By moving the cam down the rear clutch vane will retract sooner in the closing cycle.

# LWZ-2 Series

## Set up of zone lock:

- Insert the locking rod through the upper pivot assembly (see Fig. 5). Then insert the bottom half of the locking rod (the spring end) into the coupler and tighten only the lower coupler nut.
- Open door to locked position (approximately 7/8" from full closed), pull sensing bar out & away from the opening vane.
- Make sure the locking bracket rotates down to the lowest possible position. (see Fig. 5)
- Locking rod should be rotated to be parallel to the locking bracket to prevent binding between pivot and plate.
- Lightly tighten the set screw securing the locking rod to the upper pivot.
- Close car door and check that the sensing bar pulls up to the rubber stops. The spring in the coupler should be slightly compressed at this point. If the spring does not compress, then the locking cam can be adjusted by moving its position along the track.
- Also review Zone Lock & Retracting Vane on page 4.
- Fully secure the set screw in the upper pivot and tighten the jam nut.

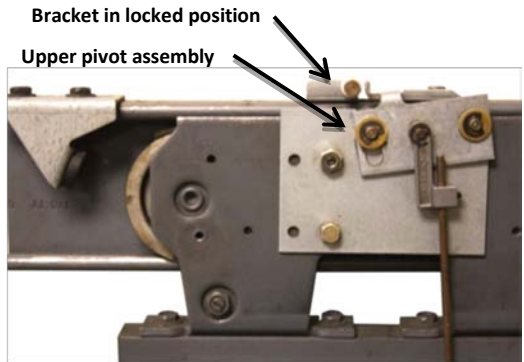
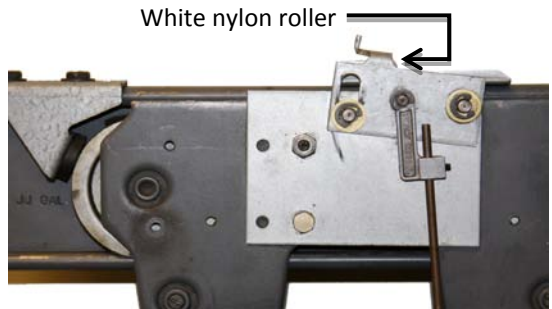

Fig. 5: Zone Lock in Locked Position

## Quick Set up of locking cam:

- With car door fully closed, position locking cam as shown so that the trailing edge of the locking bracket is just over the white nylon roller.
- Check that the locking mechanism works correctly.
- Also review Zone Lock & Retracting Vane on page 4.

**Note:** During a typical operation, the sensing bar should never drop and should be held in the retracted (raised) position by either the force of the locking cam roller or the force of the interlock release rollers.



# LWZ-2 Series

## Zone Lock & Retracting Vane Timing

The following table of pictures show how the zone lock and clutch operate together. The mark on the sheave and track indicates the cars door full closed position.

### Door is fully closed

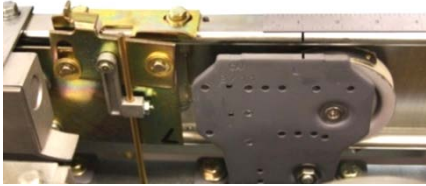

Back of the locking bracket tab is aligned with the locking cam roller

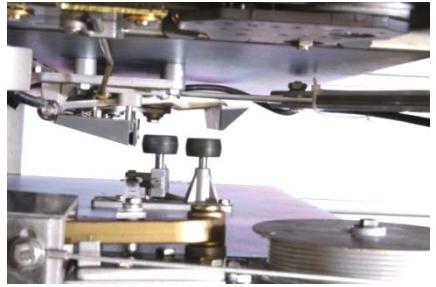

1/4" running clearance between roller & sensing vane

### 1/4" Car door travel

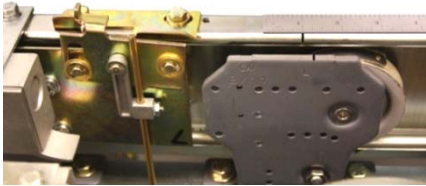

Locking bracket still on the locking cam roller



Sensing vane just contacting pickup roller

### 1/2" Car door travel



Locking bracket is still on the locking cam roller



#### **OPENING DIRECTION:**

Retracting vane is clear of roller release (despite the angle of the picture, there is a space between roller release and close vane)  
Retracting vane extending, but not engaging roller

#### **CLOSING DIRECTION:**

Retracting vane must clear roller release to avoid clipping roller release

# LWZ-2 Series

## 3/4" Car door travel (1/4" hatch door)

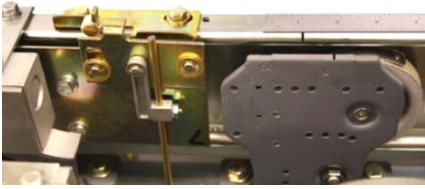

### OPENING DIRECTION:

Locking bracket is still on locking cam roller

### CLOSING DIRECTION:

Locking bracket is picking up on locking cam

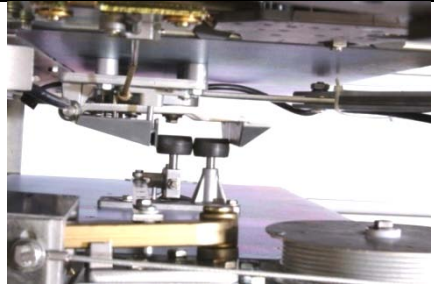

### OPENING DIRECTION:

Retracting vane engaging roller release

### CLOSING DIRECTION:

Retracting vane retraction started but not clear of roller release to ensure door closes to point that reopening will not catch zone lock

## 1" Car door travel (1/2" hatch door)

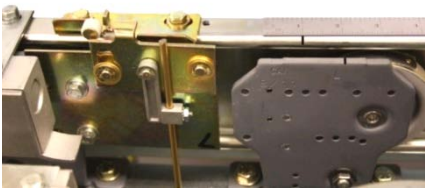

Passes zone locking position

Locking bracket is off the locking cam roller.

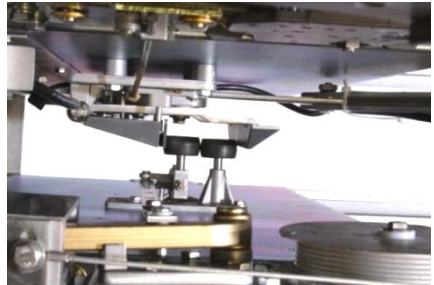

Clutch fully engaged on to roller release

Hatch door fully controlled allowing high speed

**Note:** Transition to high speed after passing zone lock.

# LWZ-2 Series

## LRC (Limited Run Clearance) Clutch Adjustments:

This section is for **LRC type clutches only**.

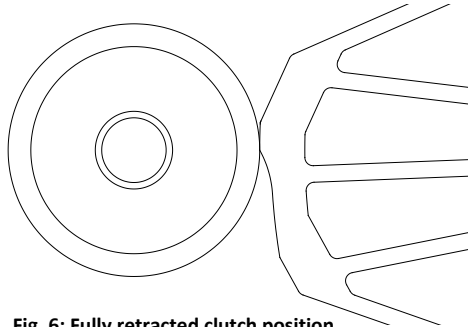
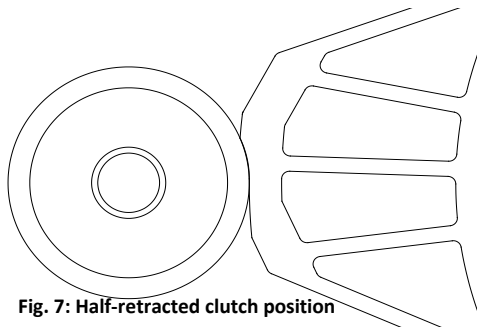

**Fig. 6: Fully retracted clutch position**

- With the cab door closed remove the 2 nuts holding the opening vane. Swing the vane open and then loosen 2 bolts holding the clutch cam.
- Adjust the cam until the nylon roller is on the outer most cam surface as shown in Fig. 6: Fully retracted clutch position

**Note:** pushing in the closing vane will unload the cam for easier adjustment. When releasing the closing vane, the cam should keep the vane in a retracted position.

- Tighten both cam bolts securely.



**Fig. 7: Half-retracted clutch position**

- Open door manually until roller is just resting at the bottom of the machined step as shown in Fig. 7. This is the half-retracted clutch position.
- If the door moves more than 1" or past the desired roller release contact point (1/4" nominally), readjust by rotating the cam up for faster vane extension.
- Then retighten the cam screws.

**NOTE:** This above procedure is to ensure that the clutch vane will start extending as soon as the door starts to open.



# LWZ-2 Series

- Open the door until the cam is fully disengaged.
- Close the opening clutch vane, ensuring that the springs are seated properly on both the vane and the base.
- Tighten the clutch-closure screw (the **UPPER SCREW ONLY** on the door opening vane) until the opening vane is 2.125 inch (2-1/8") from the base. See Fig. 8.

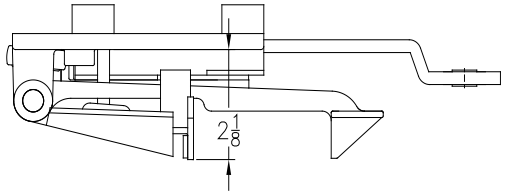
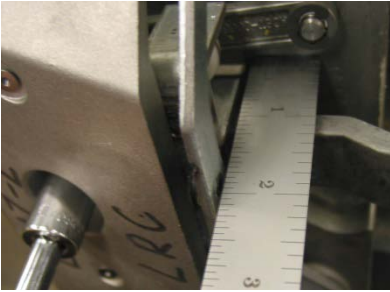

Fig. 8: Adjust **UPPER SCREW ONLY** (clutch-closure screw) to extended position

- Close the door to fully retract closing vane, and then tighten the clutch-retracting screw (the **LOWER SCREW** on the door opening vane) only until the opening vane has retracted 0.25 inch (1/4") or has moved as needed. See Fig. 9.

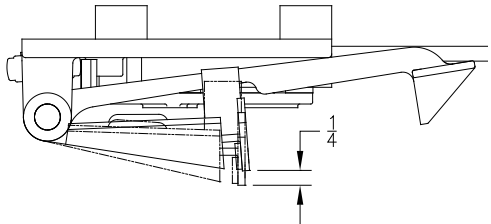

Fig. 9: Adjusting the **LOWER SCREW** (clutch retracting screw)

- Ensure the stationary roller clears closing vane by 0.0625 inch (1/16") minimum.
- Extend the movable roller to connect with as much of the retracted opening vane as possible. This should not be less than 0.125 inches (1/8"). See Fig 10.

**NOTE:** The two rollers do not need to be perfectly aligned. Make sure that the car will safely pass the roller release.

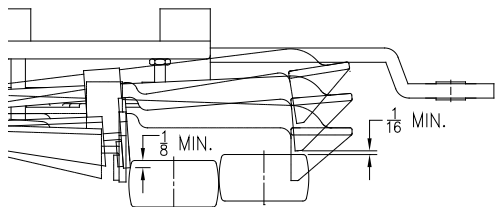
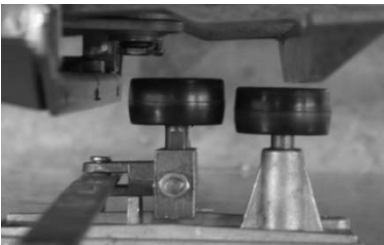
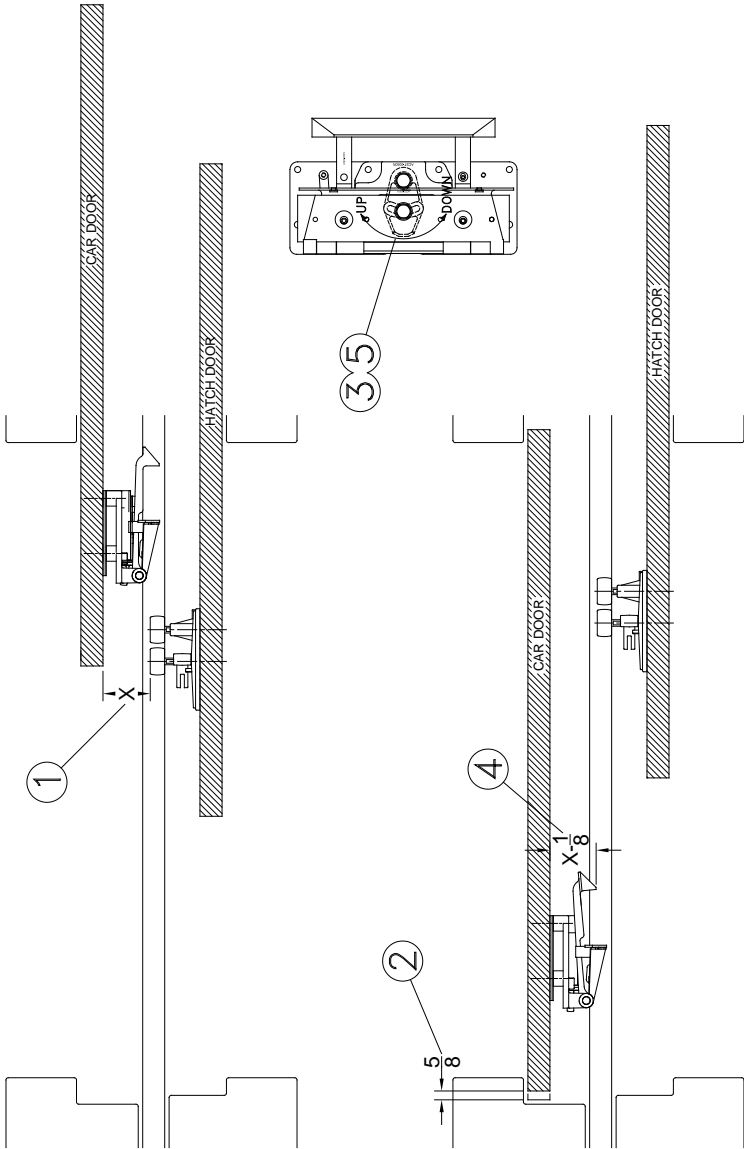

Fig 10: Adjust roller releases

# LWZ-2 Series



**Fig. 11: Open Vane Location**

1. MEASURE DISTANCE FROM DOOR FACE TO EDGE OF PICK-UP ROLLERS. NOTE DIMENSION "X".
2. POSITION CAR DOOR 5.8" FROM FULL CLOSE POSITION.
3. LOOSEN TWO (2) CAM BOLTS.
4. TURN CAM UNTIL RETRACTING VANE MEASURES 1.8" LESS THAN DIMENSION "X" (FROM THE CAR DOOR FACE).
5. TIGHTEN CLUTCH CAM IN POSITION.

# LWZ-2 Series

## STANDARD LWZ-2 CLUTCH ASSEMBLY

PARTS LIST		
ITEM	PART NUMBER	DESCRIPTION
1	HWBS-004IN	BUSHING, NYLINER PLUS 5/8 X 7/16
2	HWBS-0008N	BUSHING, NYLINER 1/4 ID X 1/4 HTG 4L4-F FLANGED TYPE 5
3	HWBS-0042N	BUSHING, NYLINER 5/16 ID X 1/8 HTG TYPE 5 FLANGED
4	HWBS-000IN	BUSHING, TYPE 7 NYLINER .251 ID X .201 LG 4L2-FF SNAP-IN TYPE 7
5	SPG-0036N	SPRING, 1 1/4" LG X .750 OD-0.063 WIRE .750 OD. CONE .380 OD. .063 WIRE- 7 1/2 TRN-MUSIC
6	SPG-008IN	SPRING, 7/8" LG X .240 OD.- 0.024 WIRE .024 WIRE- 9 TURNS-MUSIC
7	SPG-0019N	SPRING, 1 5/8" LG X 3/8" OD.- 0.037 WIRE .037 WIRE- 14 TURNS

HARDWARE AND SPACERS	
PART NUMBER	DESCRIPTION
CLU9-0045N	STANDARD CLUTCH MOUNTING HARDWARE
CLU9-0046N	LOW CLUTCH MOUNTING HARDWARE
CLUI-0053N	CLUTCH SPACER, 1/8" THICK
CLUI-0054N	CLUTCH SPACER, 1/16" THICK

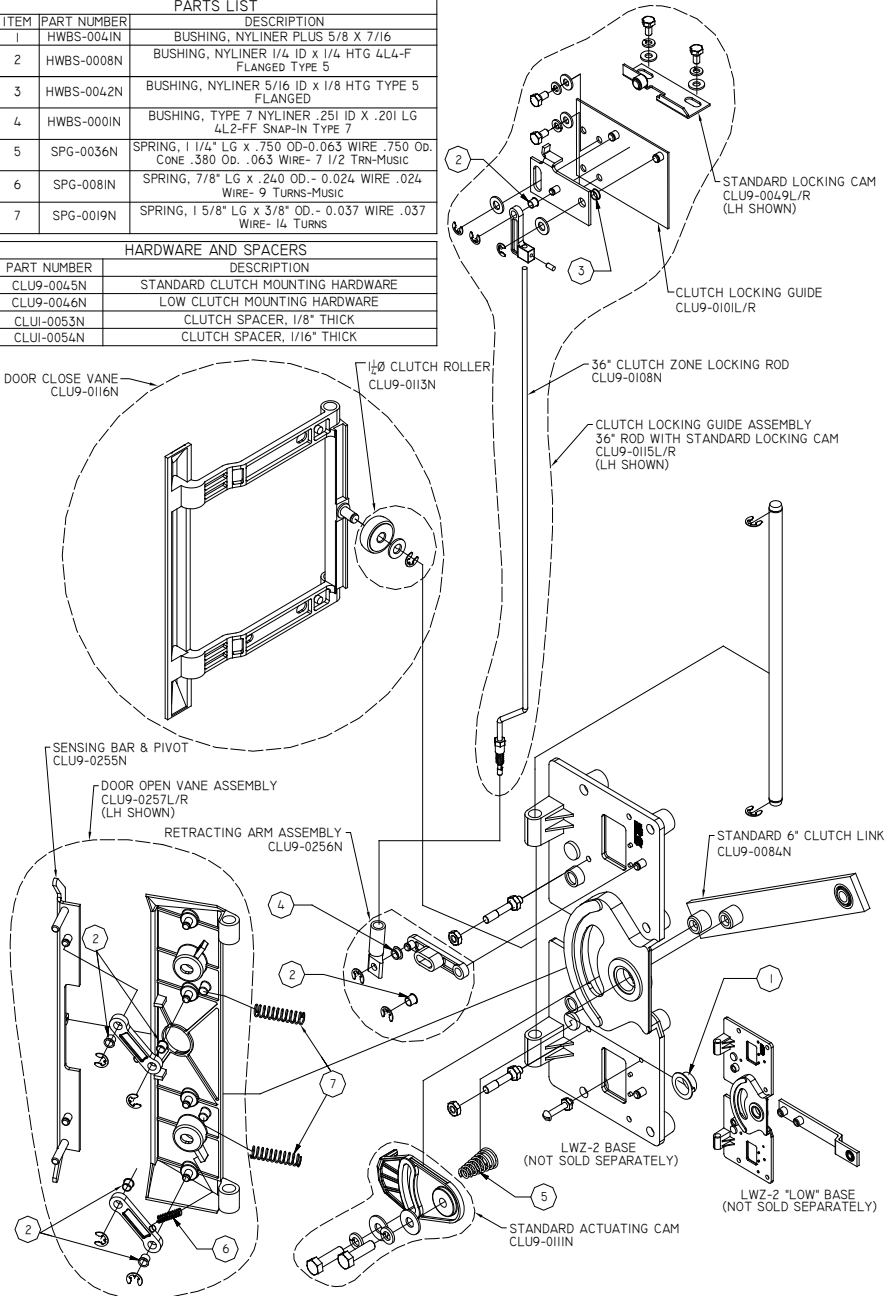
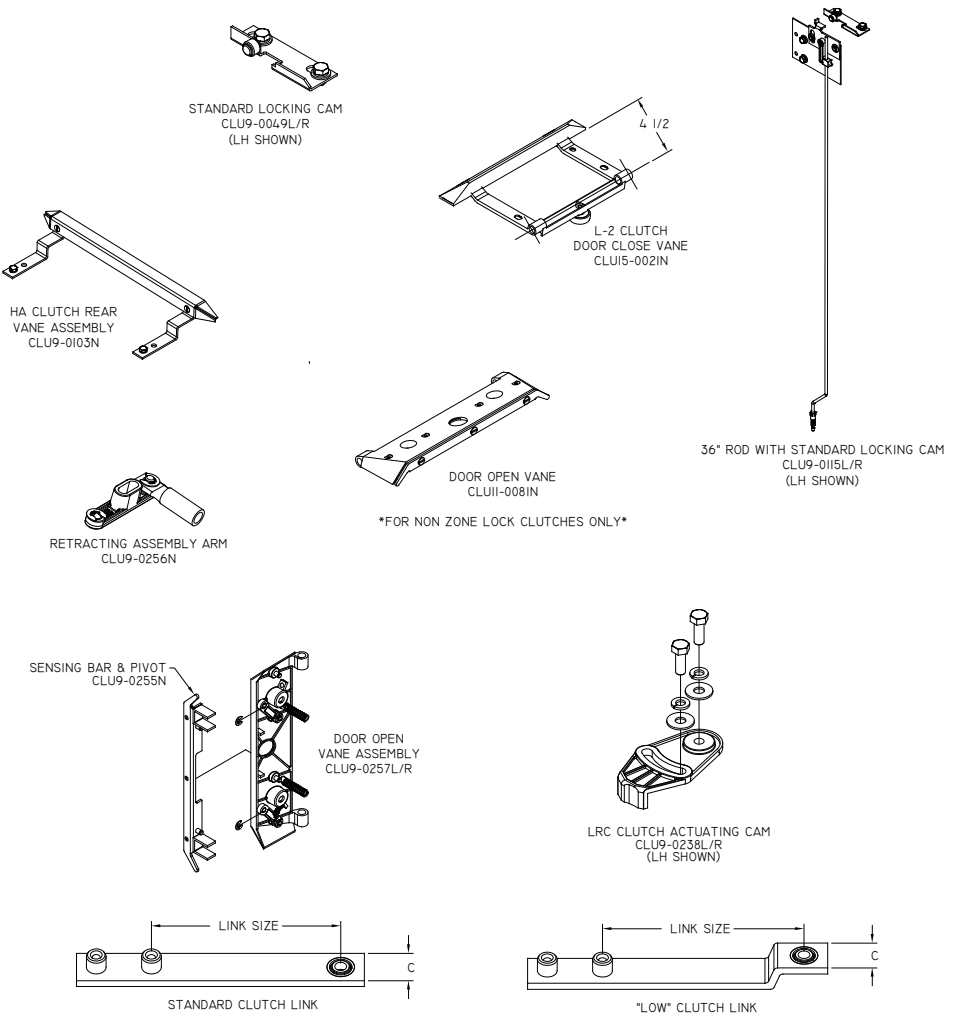

Fig. 12: Standard LWZ-2 Clutch Assembly

# LWZ-2 Series

## LWZ-2 SERIES OF CLUTCHES - ADDITIONAL COMPONENTS



CLUTCH LINKS			
*STD* PART NUMBER	"LOW" PART NUMBER	LINK SIZE	C WIDTH
CLU9-0083N	CLU9-0063N	5 1/4	1 1/4
CLU9-0084N	CLU9-0064N	6	1 1/4
CLU9-0085N	CLU9-0065N	7	1 1/4
CLU9-0086N	CLU9-0066N	8	1 1/4
CLU9-0087N	CLU9-0067N	9	1 1/4
CLU9-0088N	CLU9-0068N	10	1 1/2
CLU9-0089N	CLU9-0069N	11	1 1/2
CLU9-0090N	CLU9-0070N	12	1 1/2
CLU9-0091N	CLU9-0071N	14	1 1/2
CLU9-0092N	CLU9-0072N	16	1 1/2

Fig. 13: Select LWZ-2 Clutch replacement parts